

IX-NNW2515

Small SCARA Robot Dustproof/splash-proof type:
Arm Length 250mm, Vertical (Z) Axis 150mm



Type Dustproof/splash-proof type Arm length 250mm Load capacity 1kg rated/3kg maximum

Model items Series Model Cable length Controller type Standard I/O Expansion I/O I/O cable length Power-supply voltage
(Example) IX - NNW2515 - 5L - KX - N1 - EEE - 2 - 2

* Refer to P. 10 for details on the model items.

* The above model code represents a combination of robot and controller.

Model/Specifications

Model	Axis configuration		Arm length (mm)	Motor capacity (W)	Work envelope	Positioning repeatability (mm) (Note 1)	Maximum operating speed (Note 2)	Standard cycle time (sec) (Note 3)	Load capacity (kg)		Axis 3 push force (N)		Axis 4 allowable load	
	Axis 1	Axis 2							Rated	Maximum	Push action (Note 4)	Maximum thrust (Note 4)	Allowable inertial moment (kgm ²) (Note 5)	Allowable torque (N•m)
IX-NNW2515-5L-□-□-□-□-2	Axis 1	Arm 1	125	200	±120°	±0.010	3142mm/s (Composite speed)	0.51	1	3	65.3	90.9	0.015	1.9
	Axis 2	Arm 2	125	100	±120°									
	Axis 3	Vertical axis	—	100	150mm	±0.010	1106mm/s							
	Axis 4	Rotating axis	—	50	±360°	±0.005	1600°/s							

* In the above model code, specify the desired controller in □. For details, refer to "Explanation of SCARA Robot Model Items" (P. 10).

Common Specifications

Encode type	Absolute	Ambient temperature/humidity	Temperature: 0-40°C, humidity: 20-85%RH or below (non-condensing)
User wiring	15-conductor AWG26 waterproof connector with shield	Robot weight	21kg
User tubing	Air tube (O.D. ø4, I.D. ø2.5) x 3 (Normal working pressure 0.8MPa)	Cable length (Note 8)	5L: 5m (standard), 10L: 10m (optional)
Alarm indicator (Note 6)	Red, small LED indicator x 1 (24 VDC must be supplied.)	Protection grade (Note 9)	IP65 or equivalent
Brake-release switch (Note 7)	Brake-release switch to prevent the vertical axis from dropping (24 VDC must be supplied.)	Air purge pressure (Note 10)	0.3MPa or above (0.6MPa maximum) (Clean, dry air)

Dimensions

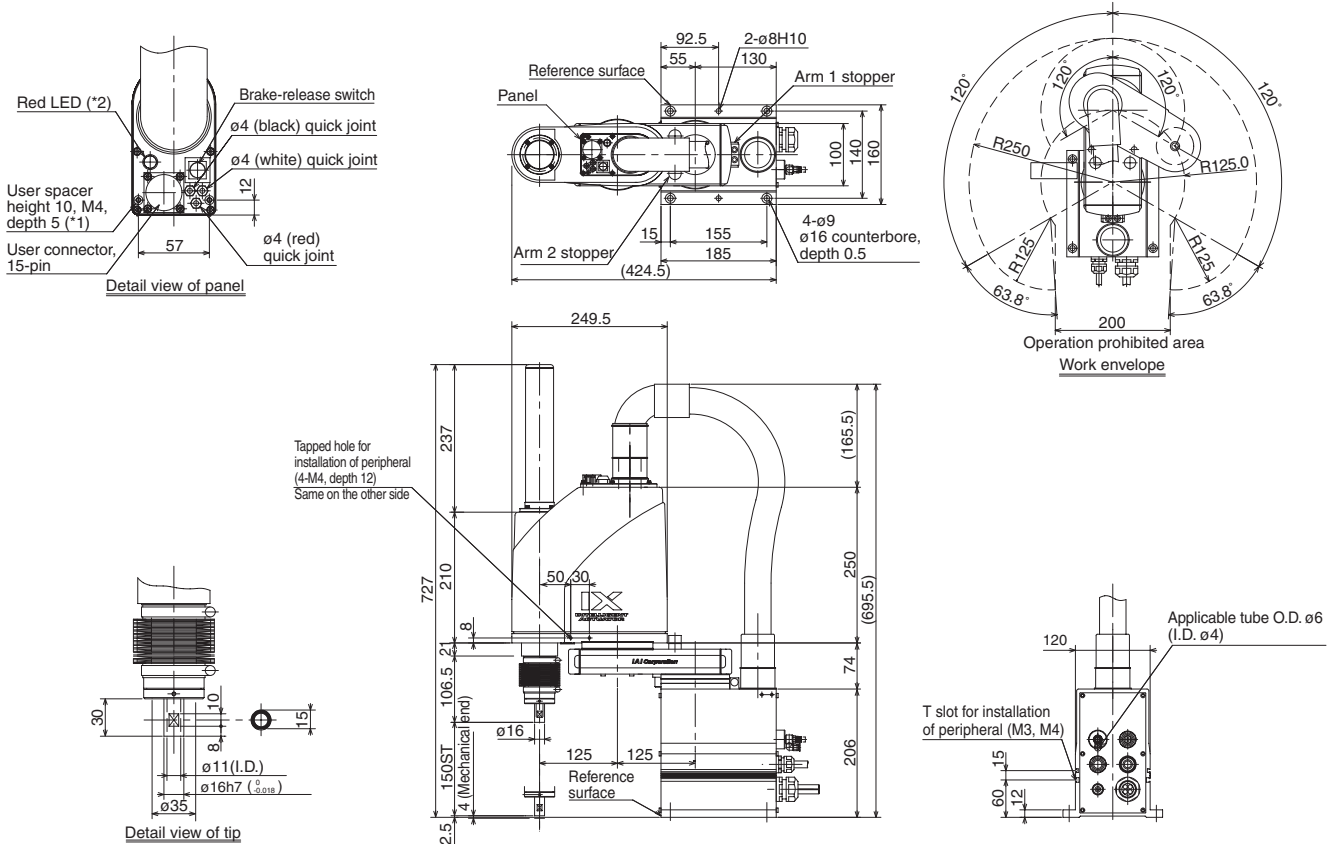

*1: The external force applied to each spacer must not exceed 30 N in the axial direction or 2 N•m in the rotating direction.
*2: To use the LED, the user must provide a circuit that takes signals from the controller's I/O output and supplies 24 VDC to the applicable LED terminal in the user connector.

- Cables/tubes
- Motor/encoder cable 5m/10m
 - Brake power cable 5m/10m
 - User cable 5m/10m
 - Air tube (4 pcs) 0.15m

Applicable Controller Specifications

Applicable controller	Features	Maximum I/O points (inputs/outputs)	Serial communication unit	Power-supply voltage	Page
XSEL-KX	General-purpose type offering excellent expandability	176/160 points	Can be installed.	AC200V	P37
XSEL-JX	Compact, space-saving type	80/64 points	Cannot be installed.		P37



Refer to P. 6 for the explanations of (Note 1) to (Note 8).