

IX-NNW50

IX Medium SCARA Robot Dustproof/splash-proof type:
Arm Length 500mm, Vertical (Z) Axis 200mm (300mm)



Type Dustproof/splash-proof type Arm length 500mm Load capacity 2kg rated/10kg maximum

Model items Series Model Cable length Controller type Standard I/O Expansion I/O I/O cable length Power-supply voltage
(Example) IX-NNW5020-5L-KX-N1-EEE-2-2

* Refer to P. 10 for details on the model items.

* The above model code represents a combination of robot and controller.

Model/Specifications

Model	Axis configuration	Arm length (mm)	Motor capacity (W)	Work envelope	Positioning repeatability (mm) (Note 1)	Maximum operating speed (Note 2)	Standard cycle time (sec) (Note 3)	Load capacity (kg)		Axis 3 push force (N)		Axis 4 allowable load	
								Rated	Maximum	Push action (Note 4)	Maximum thrust (Note 4)	Allowable inertial moment (kg·m ²) (Note 5)	Allowable torque (N·m)
IX-NNW5020-5L-KX-□-□-□-2 [IX-NNW5030-5L-KX-□-□-□-2]	Axis 1 Arm 1	250	400	±120°	±0.010	6283mm/s (Composite speed)	0.49	2	10	108	152	0.06	3.3
	Axis 2 Arm 2	250	200	±145°									
	Axis 3 Vertical axis	—	200	200mm [300mm]	±0.010	1393mm/s							
	Axis 4 Rotating axis	—	100	±360°	±0.005	1200°/s							

* In the above model code, specify the desired controller in □. For details, refer to "Explanation of SCARA Robot Model Items" (P. 10).

Common Specifications

Encode type	Absolute
User wiring	23-conductor AWG26 waterproof connector with shield
User tubing	Air tube (O.D. ø6, I.D. ø4) x 2 (Normal working pressure 0.8MPa) Air tube (O.D. ø4, I.D. ø2.5) x 2 (Normal working pressure 0.8MPa)
Alarm indicator (Note 6)	Red, small LED indicator x 1 (24 VDC must be supplied.)
Brake-release switch (Note 7)	Brake-release switch to prevent the vertical axis from dropping (24 VDC must be supplied.)

Ambient temperature/humidity	Temperature: 0-40°C, humidity: 20-85%RH or below (non-condensing)
Robot weight	32.5kg
Cable length (Note 8)	5L: 5m (standard), 10L: 10m (optional)
Protection grade (Note 9)	IP65 or equivalent
Air purge pressure (Note 10)	0.3MPa or above (0.6MPa maximum) (Clean, dry air)

Dimensions

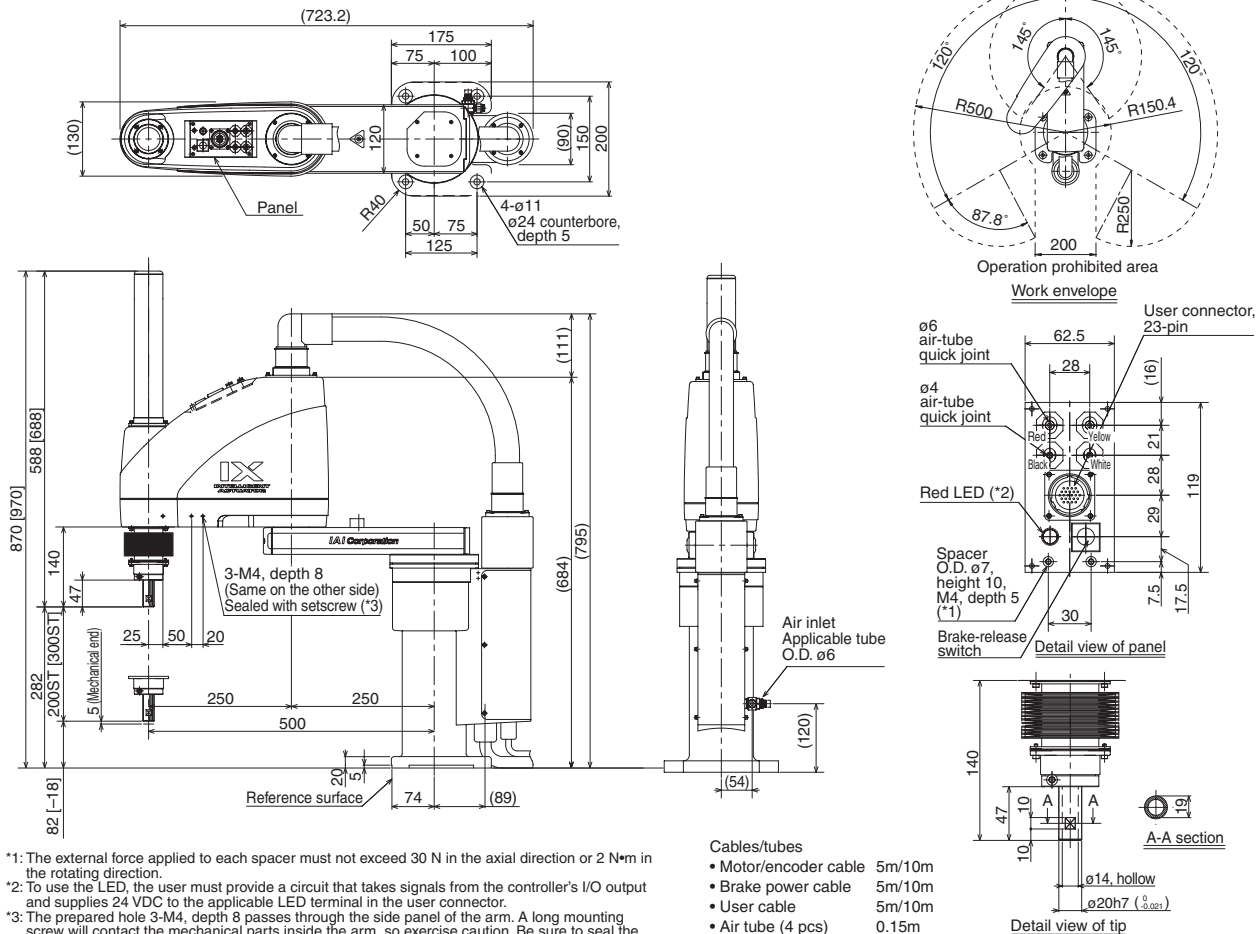

*1: The external force applied to each spacer must not exceed 30 N in the axial direction or 2 N·m in the rotating direction.
*2: To use the LED, the user must provide a circuit that takes signals from the controller's I/O output and supplies 24 VDC to the applicable LED terminal in the user connector.
*3: The prepared hole 3-M4, depth 8 passes through the side panel of the arm. A long mounting screw will contact the mechanical parts inside the arm, so exercise caution. Be sure to seal the screw by attaching sealing tape, etc.

- Cables/tubes
- Motor/encoder cable 5m/10m
- Brake power cable 5m/10m
- User cable 5m/10m
- Air tube (4 pcs) 0.15m

Applicable Controller Specifications

Applicable controller	Features	Maximum I/O points (inputs/outputs)	Serial communication unit	Power-supply voltage	Page
XSEL-KX	General-purpose type offering excellent expandability	176/160 points	Can be installed.	AC200V	P37



Refer to P. 6 for the explanations of (Note 1) to (Note 10).